



Anglicanism 101

Gathering #4:

Anglicans and the Bible

6:30-6:35 Prayer and Welcome

6:35-6:45 Small Group Time

6:45-6:55 Reports

6:55-7:00 Announcements

7:00-7:35 Anglicans & the Bible

7:35-7:55 Biblical Practice

7:55-8:00 Close in Prayer

Proper 28 *The Sunday closest to November 16*

Blessed Lord, who caused all holy Scriptures to be written for our learning: Grant us so to hear them, read, mark, learn, and inwardly digest them, that we may embrace and ever hold fast the blessed hope of everlasting life, which you have given us in our Savior Jesus Christ; who lives and reigns with you and the Holy Spirit, one God, for ever and ever. *Amen.*

Everybody Get Together



1.) What is your name?

2.) The best thing about my life
right now is...

3.) The most dangerous thing I
would like to do is...



Richard Hooker



Evelyn Underhill



Julian of
Norwich

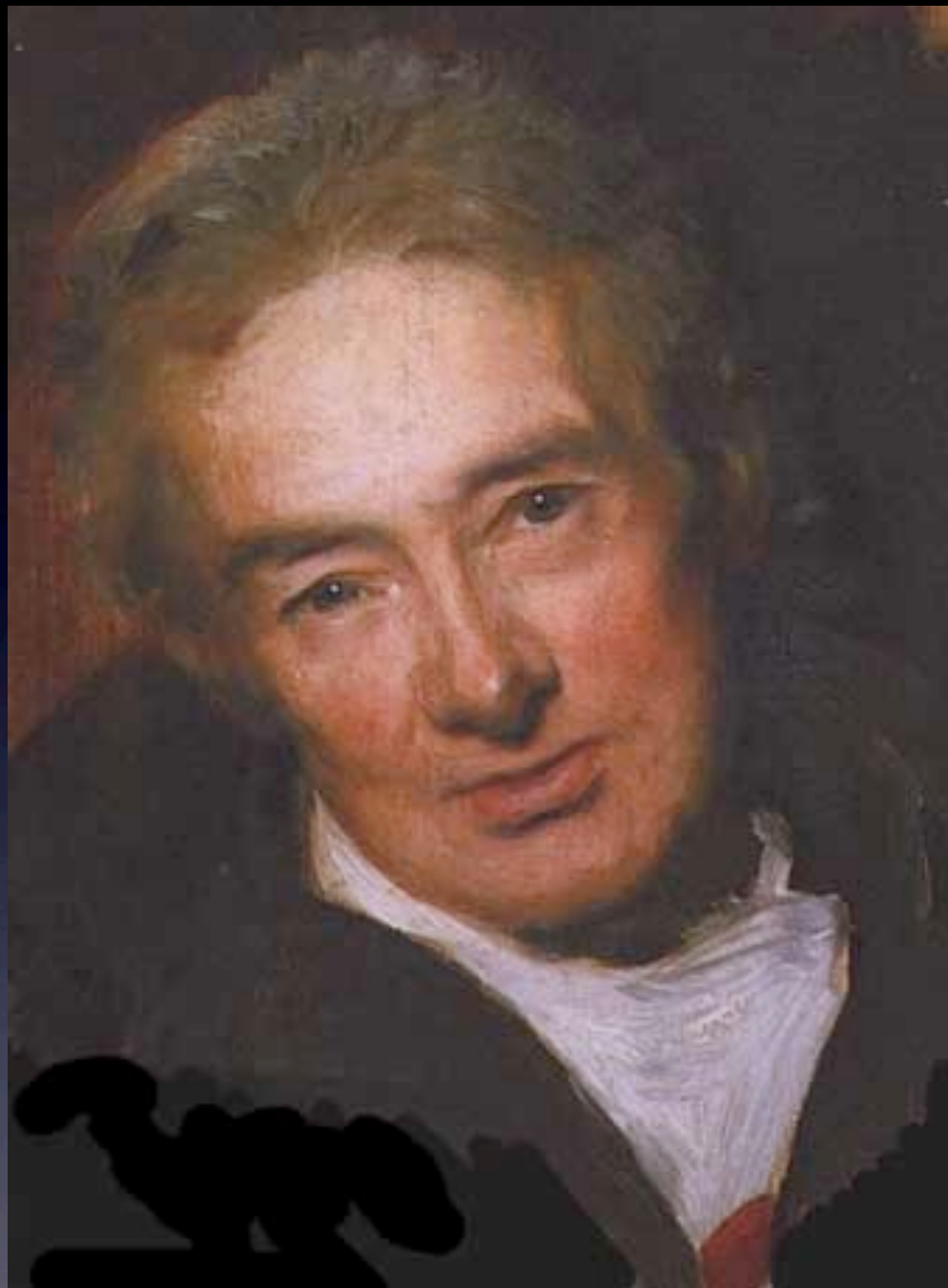

William Wilberforce

House Keeping



Anglicans and the Bible

ENGAGEMENT AND RESEARCH HISTORY

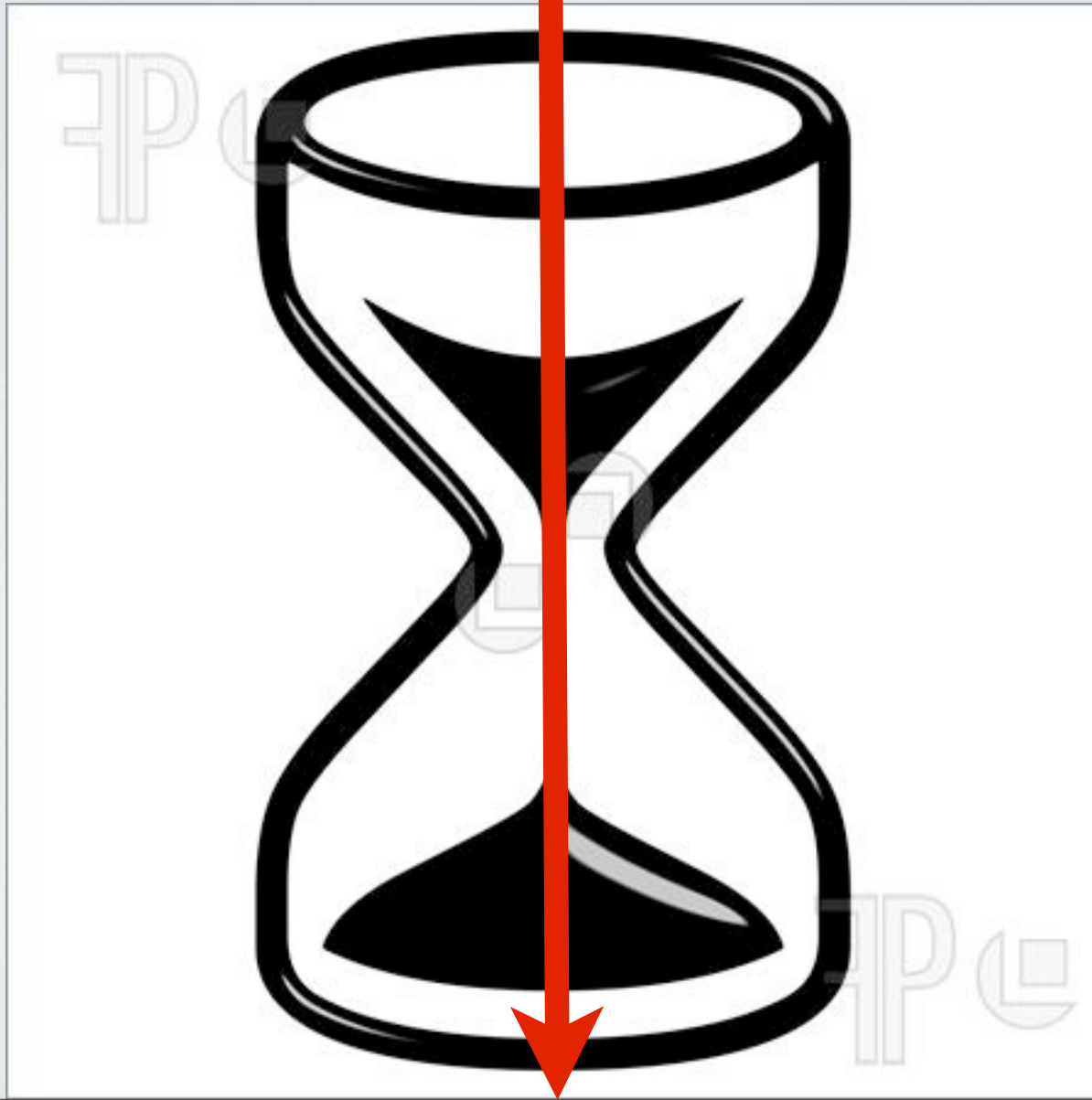



The Elizabethan Settlement *1559*

- *Act of Supremacy
& Uniformity*
- *39 Articles of
Religion*



Thomas Cranmer

Article 6

VI. Of the Sufficiency of the Holy Scriptures for Salvation.

Holy Scripture containeth all things necessary to salvation: so that whatsoever is not read therein, nor may be proved thereby, is not to be required of any man, that it should be believed as an article of the Faith, or be thought requisite or necessary to salvation. In the name of the Holy Scripture we do understand those canonical Books of the Old and New Testament, of whose authority was never any doubt in the Church.

Of the Names and Number of the Canonical Books

Genesis, The First Book of Samuel, The Book of Esther,
Exodus, The Second Book of Samuel, The Book of Job,
Leviticus, The First Book of Kings, The Psalms,
Numbers, The Second Book of Kings, The Proverbs,
Deuteronomy, The First Book of Chronicles, Ecclesiastes or Preacher,
Joshua, The Second Book of Chronicles, Cantica, or Songs of
Solomon, Judges, The First Book of Esdras, Four
Prophets the greater, Ruth, The Second Book of
Esdras, Twelve Prophets the less.

And the other Books (as Hierome saith) the Church doth read for example of life and instruction of manners; but yet doth it not apply them to establish any doctrine; such are these following:

The Third Book of Esdras, The rest of the Book of Esther,
The Fourth Book of Esdras, The Book of Wisdom,
The Book of Tobias, Jesus the Son of Sirach,
The Book of Judith, Baruch the Prophet,
The Song of the Three Children, The Prayer of Manasses,
The Story of Susanna, The First Book of Maccabees,
Of Bel and the Dragon, The Second Book of Maccabees.

All the Books of the New Testament, as they are commonly received, we do receive, and account them Canonical.

Article 7

VII. Of the Old Testament.

The Old Testament is not contrary to the New: for both in the Old and New Testament everlasting life is offered to Mankind by Christ, who is the only Mediator between God and Man, being both God and Man. Wherefore they are not to be heard, which feign that the old Fathers did look only for transitory promises. Although the Law given from God by Moses, as touching Ceremonies and Rites, do not bind Christian men, nor the Civil precepts thereof ought of necessity to be received in any commonwealth; yet notwithstanding, no Christian man whatsoever is free from the obedience of the Commandments which are called Moral.



Richard Hooker

The Anglican Way?



The Anglican Way!



Scripture

Reason

Tradition

Experience

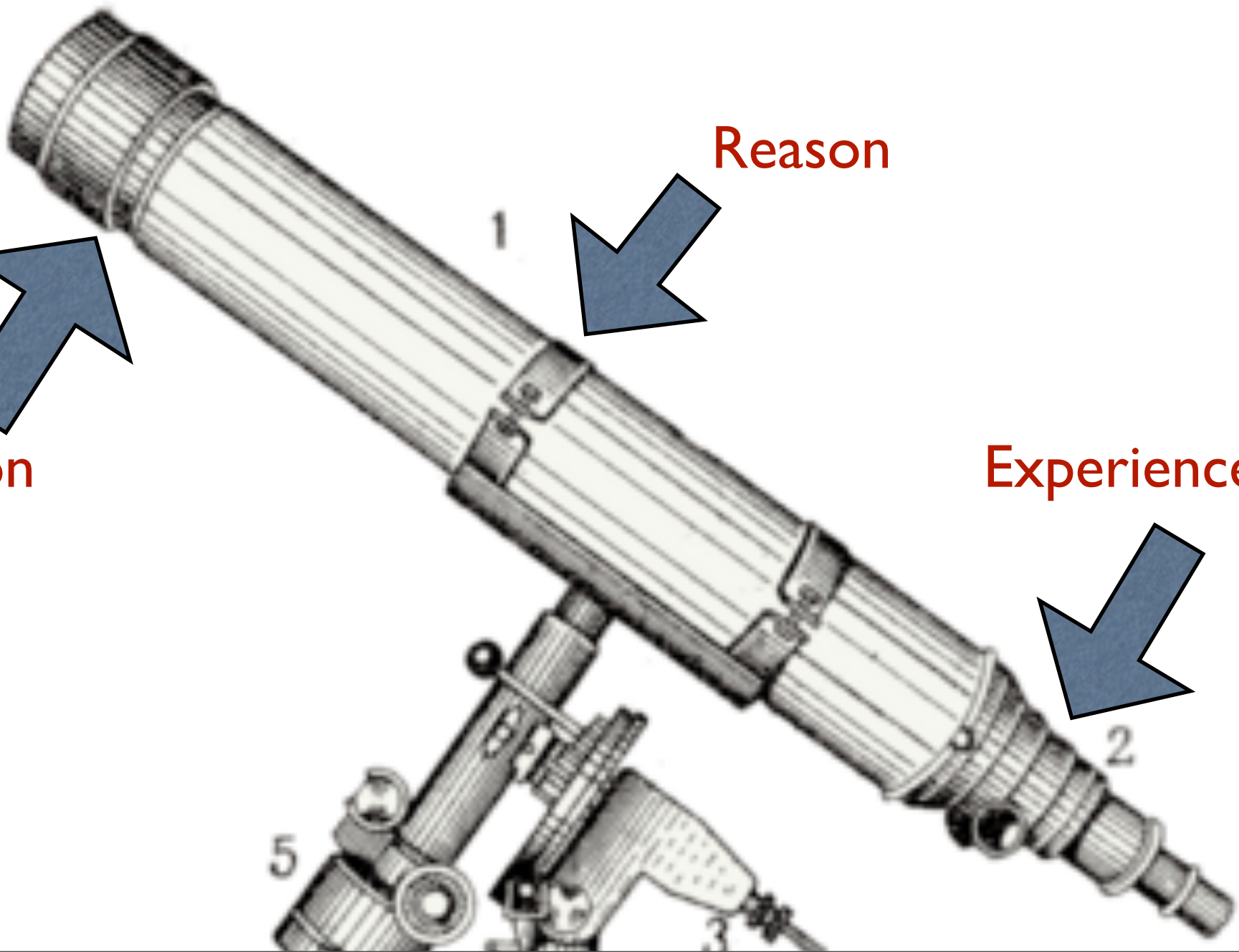
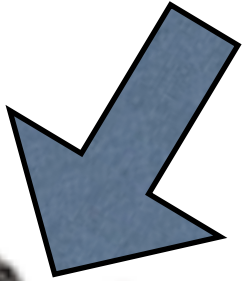
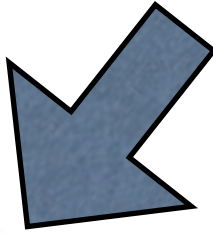
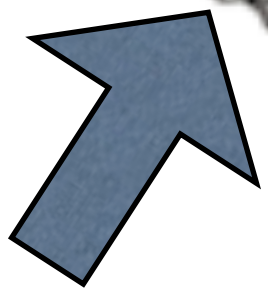

“Inerrancy”: A view from the outside



Matthew 27:6 The chief priests picked up the coins and said, "It is against the law to put this into the treasury, since it is blood money." 7 So they decided to use the money to buy the potter's field as a burial place for foreigners. 8 That is why it has been called the Field of Blood to this day. 9 Then what was spoken by **Jeremiah** the prophet was fulfilled: "They took the thirty pieces of silver, the price set on him by the people of Israel, 10 and they used them to buy the potter's field, as the Lord commanded me."^[a]

Zechariah 11:12-13

12 I told them, “If you think it best, give me my pay; but if not, keep it.” So they paid me thirty pieces of silver.

13 And the LORD said to me, “Throw it to the potter”—the handsome price at which they valued me! So I took the thirty pieces of silver and threw them to the potter at the house of the LORD.

Mark 2:25 He answered, "Have you never read what David did when he and his companions were hungry and in need? **26** In the days of **Abiathar** the high priest, he entered the house of God and ate the consecrated bread, which is lawful only for priests to eat. And he also gave some to his companions."

1 Samuel 27: 1 [a]David went to Nob, to **Ahimelek** the priest. Ahimelek trembled when he met him, and asked, “Why are you alone? Why is no one with you?”

2 David answered Ahimelek the priest, “The king sent me on a mission and said to me, ‘No one is to know anything about the mission I am sending you on.’ As for my men, I have told them to meet me at a certain place. **3** Now then, what do you have on hand? Give me five loaves of bread, or whatever you can find.”

4 But the priest answered David, “I don’t have any ordinary bread on hand; however, there is some consecrated bread here—provided the men have kept themselves from women.”

5 David replied, “Indeed women have been kept from us, as usual whenever [b] I set out. The men’s bodies are holy even on missions that are not holy. How much more so today!” **6** So the priest gave him the consecrated bread, since there was no bread there except the bread of the Presence that had been removed from before the LORD and replaced by hot bread on the day it was taken away.

The word of the Lord?



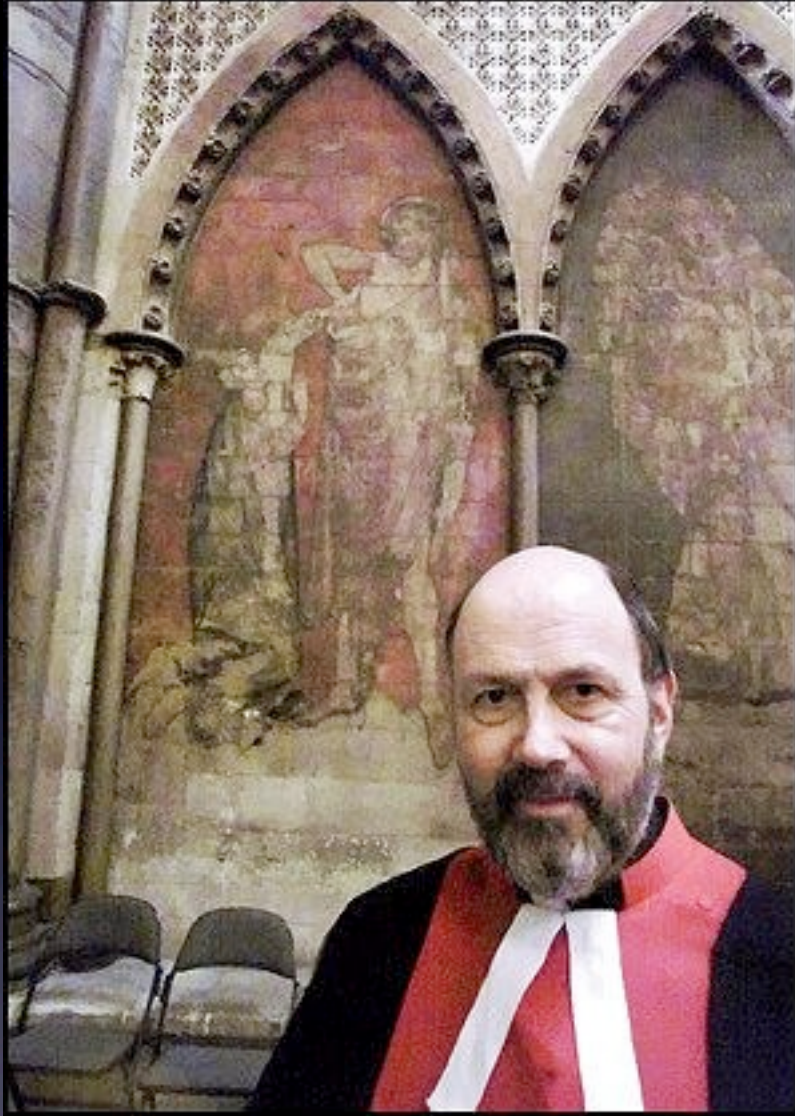

N.T. Wright

Five Act Play

I. Creation

II. Fall

III. Covenant

IV. Christ

V. Church

Faithful Improvisation



Bible + Church bring Kingdom together!

Lambeth Conference of 1888

Resolution 11

That, in the opinion of this Conference, the following Articles supply a basis on which approach may be by God's blessing made towards Home Reunion:

(a) The Holy Scriptures of the Old and New Testaments, as "containing all things necessary to salvation," and as being the rule and ultimate standard of faith.

Let's Practice

A Way to Read the Scriptures

1. I see...

- a. What does the text say? (What passages are before and after?)
- c. What questions do you have about the passage? (What do you wish you knew? What cultural issues might be affecting the passages?)

2. I think...

- a. Why do you think the author said it that way?
- b. Given what you know, what do you think the passage means? What does it mean in connection with the whole of the scriptures?

3. I wonder...

- a. How does this shape how you are living out the story of God in your life?
- b. What new questions do you now have to explore or live?

Luke 15

1 Now the tax collectors and sinners were all gathering around to hear Jesus. **2** But the Pharisees and the teachers of the law muttered, "This man welcomes sinners and eats with them."

3 Then Jesus told them this parable: **4** "Suppose one of you has a hundred sheep and loses one of them. Doesn't he leave the ninety-nine in the open country and go after the lost sheep until he finds it? **5** And when he finds it, he joyfully puts it on his shoulders **6** and goes home. Then he calls his friends and neighbors together and says, 'Rejoice with me; I have found my lost sheep.' **7** I tell you that in the same way there will be more rejoicing in heaven over one sinner who repents than over ninety-nine righteous persons who do not need to repent.

8 "Or suppose a woman has ten silver coins[**a**] and loses one. Doesn't she light a lamp, sweep the house and search carefully until she finds it? **9** And when she finds it, she calls her friends and neighbors together and says, 'Rejoice with me; I have found my lost coin.' **10** In the same way, I tell you, there is rejoicing in the presence of the angels of God over one sinner who repents."

11 Jesus continued: "There was a man who had two sons. **12** The younger one said to his father, 'Father, give me my share of the estate.' So he divided his property between them.

13 "Not long after that, the younger son got together all he had, set off for a distant country and there squandered his wealth in wild living. **14** After he had spent everything, there was a severe famine in that whole country, and he began to be in need. **15** So he went and hired himself out to a citizen of that country, who sent him to his fields to feed pigs. **16** He longed to fill his stomach with the pods that the pigs were eating, but no one gave him anything.

17 "When he came to his senses, he said, 'How many of my father's hired servants have food to spare, and here I am starving to death! **18** I will set out and go back to my father and say to him: Father, I have sinned against heaven and against you. **19** I am no longer worthy to be called your son; make me like one of your hired servants.' **20** So he got up and went to his father.

"But while he was still a long way off, his father saw him and was filled with compassion for him; he ran to his son, threw his arms around him and kissed him.

21 "The son said to him, 'Father, I have sinned against heaven and against you. I am no longer worthy to be called your son.'

22 "But the father said to his servants, 'Quick! Bring the best robe and put it on him. Put a ring on his finger and sandals on his feet. **23** Bring the fattened calf and kill it. Let's have a feast and celebrate. **24** For this son of mine was dead and is alive again; he was lost and is found.' So they began to celebrate.

25 “Meanwhile, the older son was in the field. When he came near the house, he heard music and dancing. **26** So he called one of the servants and asked him what was going on. **27** ‘Your brother has come,’ he replied, ‘and your father has killed the fattened calf because he has him back safe and sound.’

28 “The older brother became angry and refused to go in. So his father went out and pleaded with him. **29** But he answered his father, ‘Look! All these years I’ve been slaving for you and never disobeyed your orders. Yet you never gave me even a young goat so I could celebrate with my friends. **30** But when this son of yours who has squandered your property with prostitutes comes home, you kill the fattened calf for him!’

31 “‘My son,’ the father said, ‘you are always with me, and everything I have is yours. **32** But we had to celebrate and be glad, because this brother of yours was dead and is alive again; he was lost and is found.’”

Questions?

Proper 28 *The Sunday closest to November 16*

Blessed Lord, who caused all holy Scriptures to be written for our learning: Grant us so to hear them, read, mark, learn, and inwardly digest them, that we may embrace and ever hold fast the blessed hope of everlasting life, which you have given us in our Savior Jesus Christ; who lives and reigns with you and the Holy Spirit, one God, for ever and ever. *Amen.*

So what *is* the Bible
Then?

The Bible



As Sacrament and Story

The Bible

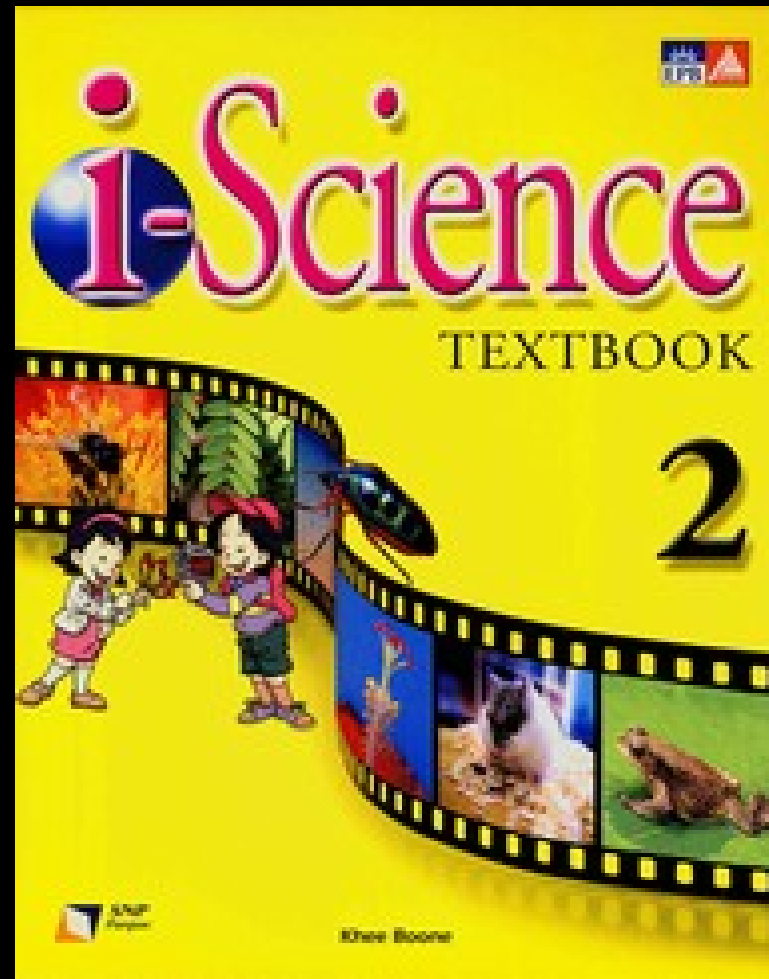

Science textbook

The Bible



Myth

The Bible

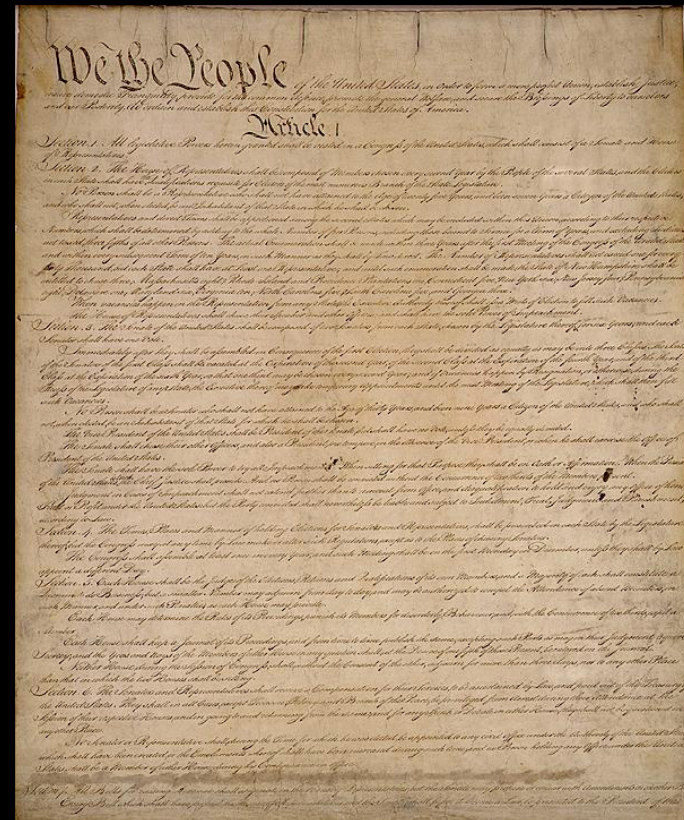

The Constitution Law book

The Bible



Psychological Symbol



Karl Barth

Three Fold Form of the Word of God

1.) Living Word (Jesus)

2.) Written Word (Scripture)

3.) Proclaimed Word (Church's
activity)